

RoHS 符合性自我声明

(深圳硕通科技股份有限公司):

为加强环境保护, 确保可持续发展, 本公司(包含子公司)在此慎重保证: 由本公司交至深圳硕通科技股份有限公司的所有要求控制有害物质含量的产品, 均符合欧盟 RoHS2.0 指令“在电子电气设备中限制使用某些有害物质指令”(2011/65/EU)和包装材料指令(94/62/EC)的规定, 具体为:

产品中有害物质含量规定:

1. 镉(Cd)及镉化合物小于 100ppm
2. 铅(Pb)及铅化合物小于 1000ppm
3. 汞(Hg)及汞化合物小于 1000ppm
4. 六价铬(Cr6+) 小于 1000ppm
5. 多溴联苯(PBBs) 小于 1000ppm
6. 多溴联苯醚(PBDE) 小于 1000ppm
7. 邻苯二甲酸二乙基己酯(DEHP) 含量小于 1000ppm
8. 邻苯二甲酸丁苯酯(BBP) 含量小于 1000ppm
9. 邻苯二甲酸二丁酯(DBP) 含量小于 1000ppm
10. 邻苯二甲酸二异丁酯(DIBP) 含量小于 1000ppm

包装材料中所含镉、铅、汞、六价铬的总含量小于 100ppm

法律法规对有害物质的含量有另外规定的依相应的法律法规执行

本公司具有完全民事和刑事责任能力, 我公司愿意承担由于我公司的声明不实而造成贵公司的所有损失承担一切赔偿及法律责任。

此份保证书对本公司及继任人具有法律效力, 不因本公司改组或签约人离职而改变其法律效力, 盖章有效。

本公司提供给 深圳硕通科技股份有限公司 的产品清单如附件一, 盖章有效。

此份保证书在双方合作期间长期有效。

公司名称: 深圳市优特佳科技有限公司

代表人: 王雄

电话: 0755-29238051

公司地址: 深圳市宝安区西乡固戍二路新安第二工业区 C11 栋 4 楼

保证日期: 2019 年 3 月 21 日

公司印章处:



附件一:

313020220 Polymer Lithium-ion Batteries;2000mAh

CERTIFICATE OF COMPLIANCE

Certificate No. : NCT16018196E1-1

Product Name : Li-ion battery

Model No : PL102050 (Other models please see the page 3 of test report)

Applicant : Shenzhen Yotoga Technology Co., Ltd.
Address : 4th, Block C11, Xinan No. 2 Industry Zone, No.2 Gushu Road, Xixiang Town, Baoan District, Shenzhen

Manufacture : Shenzhen Yotoga Technology Co., Ltd.
Address : 4th, Block C11, Xinan No. 2 Industry Zone, No.2 Gushu Road, Xixiang Town, Baoan District, Shenzhen

Trademark : N/A

The above products have been tested by us with the listed standards and found in compliance with the EUROPEAN COUNCIL EMC DIRECTIVE 2014/30/EU. It is possible to use CE marking to demonstrative the compliance with this EMC directive.

Test standards:	Report(s) Number	Issued By	Issued Date
EN 55022: 2010+AC:2011 EN 55024: 2010+A1:2015 EN 61000-3-2: 2014 EN 61000-3-3: 2013	NCT16018196E1	NCT	April. 21, 2016

This certificate of conformity is not transferable and based on an evaluation of a sample of the above mentioned product.



Date: April. 21, 2016

Signature: _____





中国认可
检验
INSPECTION
CNAS IB0078



Strategic
Partner

危险物品
DANGEROUS GOODS

航空运输条件鉴别报告书

Identification and Classification Report for Air Transport of Goods

此报告本年度有效
有效期至2019年12月31日

有效
31日

报告编号: PEKGZ20190311470GA170001

Issued No.:

签发日期:

2019.03.11

Issued Date:

委托单位: 深圳市优特佳科技有限公司

Applicant: Shenzhen Yotoga Technology Co., Ltd

物品名称: 聚合物锂离子电池 PL804050

Name of Goods: Polymer Lithium-ion Battery PL804050

北京迪捷姆空运技术开发有限公司

Beijing DGM Air Transport Technology Development Co.,Ltd.



报告书使用约定

Terms of the Using of the Report





1. 本公司依据本年度国际航协《危险品规则》以及委托人（托运人或其代理人）提供的物品及其运输信息，确定货物的航空运输条件并出具此报告书。
The report is issued by DGM China according to IATA *Dangerous Goods Regulations* published in the current year and the information of the goods and the information of its shipping provided by the applicant (shipper or his agent).
2. 依据鉴别的需要，本公司要求委托人提供真实、完整的货物样品及资料。
According to the demand of identification and classification, DGM China requires the applicant to provide true and exact sample and data of the cargo.
3. 委托人保证申报的物品和/或提供的样品与交运的货物是同一种物质。
The applicant guarantees that the declared goods and/or the sample who provides should be identical with the contents of cargo that is to be transported.
4. 本公司仅对样品的鉴别结果负责。
DGM China is only responsible for the identification and classification of the sample provided by the applicant.
5. 本报告书经主检员、审核人和批准人签字并加盖本公司印章后生效。
This report will be effective only after it is signed by the inspector, checker and approver, and stamped by DGM China.
6. 未经本公司书面批准，不得复制本报告书。
The duplicating of this report is prohibited without the written approval of DGM China.
7. 私自转让、复制、盗用、冒用、涂改、或以任何媒体形式篡改的报告书无效。
The report is invalid when anything of the following happens - illegal transfer, reproduce, embezzlement, imposture, modification or tampering in any media form.
8. 为适应国际航协《危险品规则》的年度变化，报告书仅在本年度内有效。
This report is only valid within the year in which the IATA *Dangerous Goods Regulations* is effective.

地址：北京首都国际机场货运北路天竺综合保税区BGS货运楼249室 邮编：101300

电话：010-69479673 传真：010-69479621

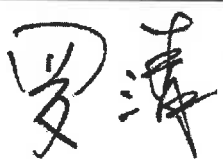
网址：www.dgmchina.com.cn E-mail: test@dgmchina.com.cn



项目编号 Item No.		PEKGZ20190311470			
物品名称 Name of Goods	中文 Chinese	聚合物锂离子电池 PL804050			
	英文 English	Polymer Lithium-ion Battery PL804050			
鉴别结论 Conclusions		<p>该货物为锂离子/聚合物电池，单独包装。额定瓦特小时为7.4Wh。已通过 UN38.3 测试，已通过包装件1.2米跌落试验，每个包装件上均有锂电池标记。</p> <p>参考有关资料，根据DGR有关规定，该物质分类识别为第9类（或项）危险品，UN3480。 This goods is lithium ion/polymer battery,packed individually.Watt-hour rating is 7.4Wh.Each battery is of a type proved to meet the Requirements of each test in the UN MANUAL OF TESTS AND CRITERIA, Part III, sub-section 38.3,Each package is capable of withstanding a 1.2m drop test in any orientation without damage to the cells contained therein, without shifting of the contents so as to allow cell to cell contact and without release of contents,Each package is marked with lithium battery mark.</p> <p>According to IATA DGR this substance is classified as dangerous goods Class (or division)9,UN3480.</p>			
建议运输条件 Suggestion for Transport Condition	UN/ID 编号 UN/ID No.	运输专用名称 Proper Shipping Name		类或项 Class or Div. (次要危险性) (Subsidiary Risk)	包装等级 Packing Group
	UN3480	Lithium ion batteries		9	
	包装说明 Packing Inst.	客货机 Passenger and Cargo Aircraft	Forbidden		
		仅限货机 Cargo Aircraft only	965, IB		
注意事项 Remarks	<p>本货物仅限货机运输。 The goods can be transported on cargo aircraft only.</p>				
主检员 Prepared by:	审核人 Checked by:		批准人 Approved by:	报告单位（盖章） Stamp	
					
					

制单： 谢春华



电池 Battery:

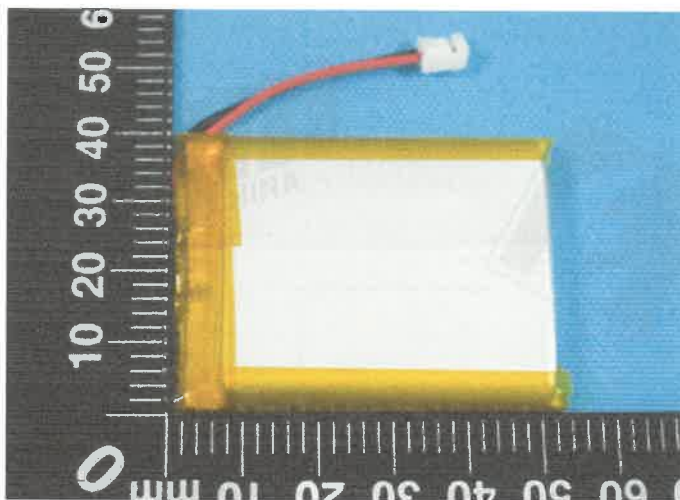
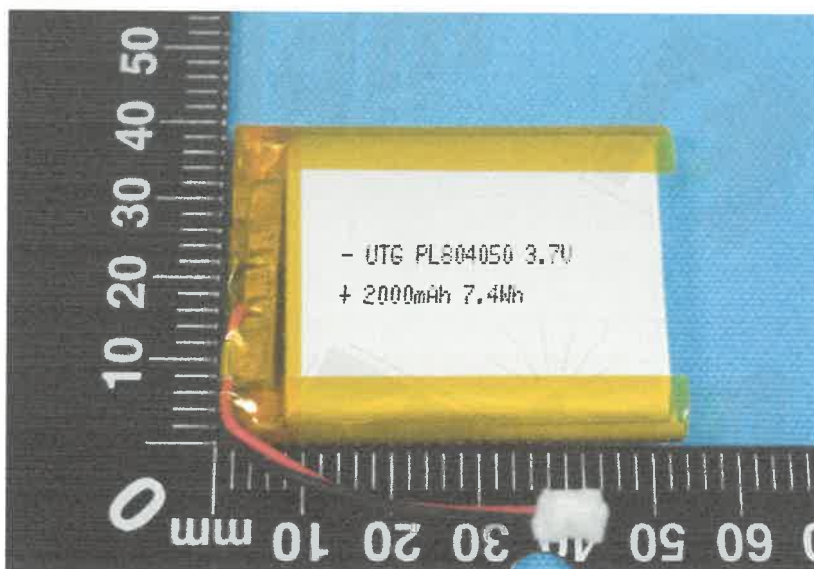

此报告
有效期至

识别分类
专用章

包装件 Package:

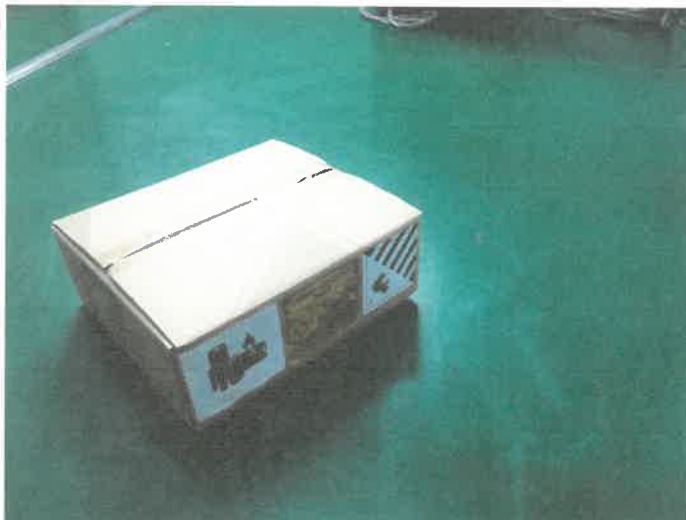

UN38.3 检测报告

UN38.3 Test Report

Client 委托方	Shenzhen Yotoga Technology Co., Ltd 深圳市优特佳科技有限公司
Add. of Client 委托方地址	4th, Block C11, Xinan No. 2 Industry Zone, No.2 Gushu Road, Xixiang Town, Baoan District, Shenzhen 深圳市宝安区西乡固戍二路新安第二工业区 C11 栋 4 楼
Samples Description 样品名称	Polymer Lithium-ion Battery 聚合物锂离子电池
Model/Type 型号规格	PL804050
Testing Laboratory 测试机构	Shenzhen NCT Testing Technology Co., Ltd. 深圳诺检测技术有限公司 1 / F, No. B Building, Mianshang Younger Pioneer Park, Hangcheng Road, Gushu Xixiang Street, Baoan District, Shenzhen, Guangdong, China 中国广东省深圳市宝安区西乡街道固戍航城大道绵商青年创业园 B 栋第 1 层
Report No. 报告编号	NCT18043212B1-1
Issued Date 发行日期	Nov. 26, 2018
Test Conclusion 测试结论: Shown in the Conclusion of test report. 见检测报告结论页.	

Tested by 主检人: Bowen Lin

Approved by 批准人: _____

Inspected by 审核人: Hely Wang

Seal of NCT 报告单位 盖章

Date of Issue 签发日期: 2018. 11. 26



I、Sample Description 样品描述

Product Name 产品名称	Polymer Lithium-ion Battery 聚合物锂离子电池	Sample Model 样品型号	PL804050		
Manufacturer 制造商	Shenzhen Yotoga Technology Co., Ltd 深圳市优特佳科技有限公司				
Address 地址	4th, Block C11, Xinan No. 2 Industry Zone, No.2 Gushu Road, Xixiang Town, Baoan District, Shenzhen 深圳市宝安区西乡固戍二路新安第二工业区 C11 栋 4 楼				
Factory 工厂	Shenzhen Yotoga Technology Co., Ltd 深圳市优特佳科技有限公司				
Address 地址	4th, Block C11, Xinan No. 2 Industry Zone, No.2 Gushu Road, Xixiang Town, Baoan District, Shenzhen 深圳市宝安区西乡固戍二路新安第二工业区 C11 栋 4 楼				
Trade Mark 商标	----	Cell Shape 电芯形状	Prismatic 棱柱形	Battery Size 电池尺寸 (L×W×T)	(52.0×40.0×8.0)mm
Nominal Voltage 标称电压	3.7V	Rated Capacity 额定容量	2000mAh 7.4Wh	Limited Charge Voltage 充电限制电压	4.2V
Standard Charge Current 标准充电电流	400mA	Maximum Continuous Charge Current 最大持续充电电流	1000mA	End Charge Current 结束充电电流	40mA
Cut-off Voltage 放电截止电压	3.0V	Standard Discharge Current 标准放电电流	400mA	Maximum Discharge Current 最大放电电流	1000mA
Cell Number 组成电芯数量	1PCS		Cell Model 电芯型号	PL804050	
Receiving Date 接收日期	Oct. 23, 2018		Completing Date 完成日期	Nov. 06, 2018	

II、Standard 标准

UNITED NATIONS "Recommendations on the Transport of Dangerous Goods, Manual of Tests and Criteria" (ST/SG/AC.10/11/Rev.6 Section 38.3)

联合国《关于危险货物运输的建议书 实验和标准手册》第六修订版第 38.3 节。

III、Test Item 测试项目

- | | |
|---|--|
| T.1. <input checked="" type="checkbox"/> Altitude simulation 高度模拟 | T.5. <input checked="" type="checkbox"/> External short circuit 外部短路 |
| T.2. <input checked="" type="checkbox"/> Thermal test 温度试验 | T.6. <input type="checkbox"/> Impact / <input checked="" type="checkbox"/> Crush 撞击/挤压 |
| T.3. <input checked="" type="checkbox"/> Vibration 振动 | T.7. <input checked="" type="checkbox"/> Overcharge 过充电 |
| T.4. <input checked="" type="checkbox"/> Shock 冲击 | T.8. <input checked="" type="checkbox"/> Forced discharge 强制放电 |

IV、Test Method and Requirement 测试方法和要求

Tests T.1 to T.5 shall be conducted in sequence on the same cell or battery. Tests T.6 and T.8 shall be conducted using not otherwise tested cells. Test T.7 may be conducted using undamaged batteries previously used in tests T.1 to T.5 for purposes of testing on cycled batteries.

用相同的电芯或电池按照顺序进行试验 T.1 至 T.5。试验 T.6 至 T.8 用没有进行其他试验的电芯。试验 T7 可以使用原先在试验 T1 至 T5 中使用过的未损坏的电池进行，以便测试交替充电放电的电池。

Single cell batteries of B1#~B14# are full charged after one cycle;
 Single cell batteries of B15#~B18# are full charged after fifty cycles;
 Rechargeable cells of C19#~C23# are 50% charged after one cycle;
 Rechargeable cells of C24#~C33# are full discharged after one cycle;
 Rechargeable cells of C34#~C43# are full discharged after fifty cycle;
 Test environment condition: ambient temperature: 15-25°C, ambient humidity: 40-70%

单电芯电池 B1#~B14#为一次循环满电状态;
 单电芯电池 B15#~B18#为 50 次循环满电状态;
 可充电电芯 C19#~C23#为一次循环后 50%充电状态;
 可充电电芯 C24#~C33#为一次循环完全放电状态;
 可充电电芯 C34#~C43#为 50 次循环完全放电状态;
 试验环境条件: 环境温度: 15-25°C, 环境湿度: 40-70%

In order to quantify the mass loss, the following procedure is provided:

$$\text{Mass loss (\%)} = (M1-M2)/M1 \times 100$$

质量损失的量化值，可用以下公式计算：

$$\text{质量损失(\%)}=(M1-M2)/M1 \times 100$$

Where M1 is the mass before the test and M2 is the mass after the test. When mass loss does not exceed the values in Table below, it shall be considered as "no mass loss".

式中：M1 是试验前的质量，M2 是试验后的质量。如果质量损失不超过下表所列的数值，应视为“无质量损失”。

Mass M of cell or battery 电芯或电池的质量	Mass loss limit 质量损失限值
M<1g	0.5%
1g≤M≤75g	0.2%
M>75g	0.1%

Leakage means the visible escape of electrolyte or other material from a cell or battery or the loss of material (except battery casing, handling devices or labels) from a cell or battery such that the loss of mass exceeds the values in Table above.

渗漏系指可以看到的电解液或者其他物质从电芯或者电池中漏出，或电芯或电池中的物质损失（不包括

电池外壳、搬运装置、或标签)，失去的质量超过上表所列的数值。

In test T.1 to T.4, cells and batteries meet this requirement if there is no leakage, no venting, no disassembly, no rupture and no fire and if the open circuit voltage of each test cell or battery after testing is not less than 90% of its voltage immediately prior to this procedure. The requirement relating to voltage is not applicable to test cells and batteries at fully discharged states.

在测试 T.1 至 T.4 中，电芯和电池须满足无渗漏、无泄气、无解体、无破裂和无起火，并且每个试验电芯或电池在试验后的开路电压不小于其在进行这一试验前电压的 90%。

T.1. Altitude simulation 高度模拟

Test method 测试方法

Test cells and batteries are stored at a pressure of 11.6 kPa or less for at least six hours at ambient temperature (20±5°C).

试验电芯和电池被放置在压力等于或低于 11.6 kPa 和环境温度(20±5°C)下存放至少 6 小时。

Requirement 要求

Cells and batteries meet this requirement if there is no leakage, no venting, no disassembly, no rupture and no fire and if the open circuit voltage of each test cell or battery after testing is not less than 90% of its voltage immediately prior to this procedure.

电芯和电池须无渗漏、无泄气、无解体、无破裂和无起火，并且每个试验电芯或电池在试验后的开路电压不小于其在进行这一试验前电压的 90%。

T.2. Thermal test 温度试验

Test method 测试方法

Test cells and batteries are to be stored for at least six hours at a test temperature equal to 72±2°C, followed by storage for at least six hours at a test temperature equal to -40±2°C. The maximum time interval between test temperature extremes is 30 minutes. This procedure is to be repeated until 10 total cycles are complete, after which all test cells and batteries are to be stored for 24 hours at ambient temperature (20±5°C). For large cells and batteries the duration of exposure to the test temperature extremes should be at least 12 hours.

试验电芯和电池放置在试验温度等于 72±2°C 的条件下存放至少 6 小时，接着再在试验温度等于 -40±2°C 的条件下存放至少 6 小时。两个极端试验温度之间的最大时间间隔为 30 分钟。此程序重复进行，共完成 10 次循环，接着将所有试验电芯和电池在环境温度(20±5°C)下存放 24 小时。对于大型电芯和电池，暴露于极端试验温度的时间至少应为 12 小时。

Requirement 要求

Cells and batteries meet this requirement if there is no leakage, no venting, no disassembly, no rupture and no fire and if the open circuit voltage of each test cell or battery after testing is not less than 90% of its voltage immediately prior to this procedure.

电芯和电池须无渗漏、无泄气、无解体、无破裂和无起火，并且每个试验电芯或电池在试验后的开路电压不小于其在进行这一试验前电压的 90%。

T.3. Vibration 振动

Test method 测试方法

Cells and batteries are firmly secured to the platform of the vibration machine without distorting the cells in such a manner as to faithfully transmit the vibration. The vibration shall be a sinusoidal waveform with a logarithmic sweep between 7 Hz and 200 Hz and back to 7 Hz traversed in 15 minutes. This cycle shall be repeated 12 times for a total of 3 hours for each of three mutually perpendicular mounting positions of the cell. One of the directions of vibration must be perpendicular to the terminal face.

电芯和电池紧固于振动台台面，但不得造成电芯变形，并能准确可靠地传播振动。振动应是正弦波形，对数扫描频率在 7 Hz 和 200 Hz 之间，再回到 7 Hz，跨度为 15 分钟。这一振动过程须对三个互相垂直的电芯安装方位的每一方向重复进行 12 次，总共为时 3 小时。其中一个振动方向必须与端面垂直。

The logarithmic frequency sweep shall differ for cells and batteries with a gross mass of not more than 12 kg (cells and small batteries), and for batteries with a gross mass of more than 12 kg (large batteries).

作对数式频率扫描，对电芯和总质量不超过 12 千克的电池（电芯和小型电池），和对质量超过 12 千克的电池（大型电池）有所不同。

For cells and small batteries : from 7 Hz a peak acceleration of 1 gn is maintained until 18 Hz is reached. The amplitude is then maintained at 0.8 mm (1.6 mm total excursion) and the frequency increased until a peak acceleration of 8 gn occurs (approximately 50 Hz). A peak acceleration of 8 gn is then maintained until the frequency is increased to 200 Hz.

对电芯和小型电池：从 7 Hz 开始，保持 1 gn 的最大加速度，直到频率达到 18 Hz。然后将振幅保持在 0.8mm（总位移 1.6mm），并增加频率直到峰值加速度达到 8 gn（频率约为 50 Hz）。将峰值加速度保持在 8 gn 直到频率增加到 200 Hz。

For large batteries : from 7 Hz a peak acceleration of 1 gn is maintained until 18 Hz is reached. The amplitude is then maintained at 0.8 mm (1.6 mm total excursion) and the frequency increased until a peak acceleration of 2 gn occurs (approximately 25 Hz). A peak acceleration of 2 gn is then maintained until the frequency is increased to 200 Hz.

对大型电池：从 7 Hz 开始，保持 1 gn 的最大加速度，直到频率达到 18 Hz。然后将振幅保持在 0.8mm（总位移 1.6mm），并增加频率直到峰值加速度达到 2 gn（频率约为 25Hz）。将峰值加速度保持在 2 gn 直到频率增加到 200 Hz。

Requirement 要求

Cells and batteries meet this requirement if there is no leakage, no venting, no disassembly, no rupture and no fire and if the open circuit voltage of each test cell or battery after testing is not less than 90% of its voltage immediately prior to this procedure.

电芯和电池须无渗漏、无泄气、无解体、无破裂和无起火，并且每个试验电芯或电池在试验后的开路电压不小于其在进行这一试验前电压的 90%。

T.4. Shock 冲击

Test method 测试方法

Test cells and batteries shall be secured to the testing machine by means of a rigid mount which will support all mounting surfaces of each test battery.

试验电芯和电池用刚性支架紧固在试验装置上，支架支撑着每个试验电池的所有安装面。

Each cell shall be subjected to a half-sine shock of peak acceleration of 150 gn and pulse duration of 6 milliseconds. Alternatively, large cells may be subjects to a half-sine shock of peak acceleration of 50 gn and pulse duration of 11 milliseconds.

每个电芯须经受峰值加速度 150 gn 和脉冲持续时间 6 ms 的半正弦波冲击。不过，大型电芯须经受峰值加速度 50 gn 和脉冲持续时间 11 ms 的半正弦波冲击。

Each battery shall be subjected to a half-sine shock of peak acceleration depending on the mass of the battery. The pulse duration shall be 6 milliseconds for small batteries and 11 milliseconds for large batteries. The formulas below are provided to calculate the appropriate minimum peak accelerations.

每个电池须经受半正弦波冲击，峰值加速度需要根据电池的重量来决定。小型电池的脉冲持续时间为 6 ms，大型电池的脉冲持续时间为 11ms。下面的公式是用来计算合适的最小峰值加速度。

Battery	Minimum peak acceleration	Pulse duration
Small batteries	150 g _n or result of formula $Acceleration(g_n) = \sqrt{\left(\frac{100850}{mass^*}\right)}$ whichever is smaller	6 ms
Large batteries	50 g _n or result of formula $Acceleration(g_n) = \sqrt{\left(\frac{30000}{mass^*}\right)}$ whichever is smaller	11 ms

* Mass is expressed in kilograms.

电池	最小峰值加速度	脉冲持续时间
小型电池	150 gn 或计算结果中取最小的值 $加速度(g_n) = \sqrt{\left(\frac{100850}{mass}\right)}$	6ms
大型电池	50 gn 或计算结果中取最小的值 $加速度(g_n) = \sqrt{\left(\frac{30000}{mass}\right)}$	11 ms

Each cell or battery shall be subjected to three shocks in the positive direction and to three shocks in the negative direction in each of three mutually perpendicular mounting positions of the cell or battery for a total of 18 shocks.

每个电芯或电池须在三个互相垂直的电芯或电池安装方位的正方向经受三次冲击，接着在反方向经受三次冲击，总共经受 18 次冲击。

Requirement 要求

Cells and batteries meet this requirement if there is no leakage, no venting, no disassembly, no rupture and no fire and if the open circuit voltage of each test cell or battery after testing is not less than 90% of its voltage immediately prior to this procedure.

电芯和电池须无渗漏、无泄气、无解体、无破裂和无起火，并且每个试验电芯或电池在试验后的开路电压不小于其在进行这一试验前电压的 90%。

T.5. External short circuit 外部短路

Test method 测试方法

The cell or battery to be tested shall be heated for a period of time necessary to reach a homogeneous stabilized temperature of 57±4°C, measured on the external case. This period of time depends on the size and design of the cell or battery and should be assessed and documented. If this assessment is not feasible, the exposure time shall be at least 6 hours for small cells and small batteries, and 12 hours for large cells and large batteries. Then the cell or battery at 57±4°C shall be subjected to one short circuit condition with a total external resistance of less than 0.1 ohm.

试验电芯或电池需要加热一段时间，使其外壳温度均匀稳定地达到 57±4°C。加热时间的长短是由电芯或电池的尺寸和设计来决定的，这个加热时间需要评估并记录。如果这个加热时间不好评估的话，对于小电芯和小电池需要在此温度下放置至少 6 个小时，对于大电芯和大电池至少放置 12 个小时。然后使电芯或电池在 57±4°C 下经受总外电阻小于 0.1Ω 的短路条件。

This short circuit condition is continued for at least one hour after the cell or battery external case

temperature has returned to $57\pm 4^{\circ}\text{C}$, or in the case of the large batteries, has decreased by half of the maximum temperature increase observed during the test and remains below that value.

短路测试持续到电芯或电池外壳温度回到 $57\pm 4^{\circ}\text{C}$ 后至少持续 1 小时，针对大电池，外壳温度需要下降到测试过程中监控到的最大温度的一半以下。

The short circuit and cooling down phases shall be conducted at least at ambient temperature.

短路测试和冷却阶段至少应该在环境温度下进行。

Requirement 要求

Cells and batteries meet this requirement if their external temperature does not exceed 170°C and there is no disassembly, no rupture and no fire during the test and within six hours after test.

电芯和电池外壳温度不超过 170°C ，并且在试验过程中及试验后 6 小时内无解体、无破裂，无起火。

T.6. Impact / Crush 撞击/挤压

Test procedure – Impact (applicable to cylindrical cells not less than 18.0 mm in diameter)

测试步骤 – 撞击（适用于直径大于等于 18.0 毫米以上的圆柱形电芯）

The test sample cell or component cell is to be placed on a flat smooth surface. A $15.8\text{ mm} \pm 0.1\text{ mm}$ diameter, at least 6 cm long, or the longest dimension of the cell, whichever is greater, Type 316 stainless steel bar is to be placed across the centre of the sample. A $9.1\text{ kg} \pm 0.1\text{ kg}$ mass is to be dropped from a height of $61 \pm 2.5\text{ cm}$ at the intersection of the bar and sample in a controlled manner using a near frictionless, vertical sliding track or channel with minimal drag on the falling mass. The vertical track or channel used to guide the falling mass shall be oriented 90 degrees from the horizontal supporting surface.

试样电芯或电芯组件放在平坦光滑表面上，一根 316 型不锈钢棒横放在试样中心，钢棒直径 15.8 毫米 ± 0.1 毫米，长度至少 6 厘米，或电芯最长端的尺度，取二者之长者。将一块 9.1 千克 ± 0.1 千克的重锤从 61 ± 2.5 厘米高度跌落到钢棒和试样交叉处，使用一个几乎没有摩擦的、对落体重锤阻力最小的垂直轨道或管道加以控制。垂直轨道或管道用于引导落锤沿与水平支撑表面呈 90 度落下。

The test sample is to be impacted with its longitudinal axis parallel to the flat surface and perpendicular to the longitudinal axis of the $15.8\text{ mm} \pm 0.1\text{ mm}$ diameter curved surface lying across the centre of the test sample. Each sample is to be subjected to only a single impact.

受撞击的试样，纵轴应与平坦表面平行并与横放在试样中心的直径 15.8 ± 0.1 毫米弯曲表面的纵轴垂直。每一试样只经受一次撞击。

Test procedure – Crush (applicable to prismatic, pouch, coin/button cells and cylindrical cells less than 18.0 mm in diameter)

测试步骤– 挤压（适用于棱柱形，袋状，硬币/纽扣电芯和圆柱形电芯直径小于 18.0 毫米）

A cell or component cell is to be crushed between two flat surfaces. The crushing is to be gradual with a speed of approximately 1.5 cm/s at the first point of contact. The crushing is to be continued until the first of the three options below is reached.

将电芯或电芯组件放在两个平面之间挤压，挤压力度逐渐加大，在第一个接触点上的速度大约为 1.5 cm/s。挤压持续进行，直到出现以下三种情况之一：

- (a) The applied force reaches $13\text{ kN} \pm 0.78\text{ kN}$;
- (b) The voltage of the cell drops by at least 100 mV;
- (c) The cell is deformed by 50% or more of its original thickness.

(a)施加的力达到 $13\text{ kN} \pm 0.78\text{ kN}$;

(b)电芯的电压下降至少 100mV;

(c)电芯形变达到原始厚度的 50%或更多。

Once the maximum pressure has been obtained, the voltage drops by 100 mV or more, or the cell is deformed by at least 50% of its original thickness, the pressure shall be released.

一旦达到最大压力、电压下降 100mV 或更多，或电芯形变至少达到原始厚度的 50%，即可解除压力。

A prismatic or pouch cell shall be crushed by applying the force to the widest side. A button/coin cell

shall be crushed by applying the force on its flat surfaces. For cylindrical cells, the crush force shall be applied perpendicular to the longitudinal axis.

棱柱形或袋装电芯须从最宽的面施压。纽扣/硬币形电芯应从其平坦表面施压。圆柱形电芯应从与纵轴垂直的方向施压。

Each test cell or component cell is to be subjected to one crush only. The test sample shall be observed for a further 6 h. The test shall be conducted using test cells or component cells that have not previously been subjected to other tests.

每个试样电芯或电芯组件只做一次挤压试验。试样须继续观察 6 小时。试验须使用之前未做过其他试验的试样电芯或电芯组件进行。

Requirement 要求

Cell and component cells meet this requirement if their external temperature does not exceed 170°C and there is no disassembly and no fire during the test and within six hours after test.

电芯和电芯组件外壳温度不超过 170°C，并且在试验过程中及试验后 6 小时内无解体，无起火。

T.7. Overcharge 过充电

Test method 测试方法

The charge current shall be twice the manufacturer's recommended maximum continuous charge current. The minimum voltage of the test shall be as follows:

充电电流为制造商推荐的最大持续充电电流的两倍。试验的最小电压如下：

- (a) When the manufacturer's recommended charge voltage is not more than 18V, the minimum voltage of the test shall be the lesser of two times the maximum charge voltage of the battery or 22V.
- (b) When the manufacturer's recommended charge voltage is more than 18V, the minimum voltage of the test shall be 1.2 times the maximum charge voltage.

(a) 制造商推荐的充电电压不大于 18 伏时，试验的最小电压应是电池最大充电电压的两倍或 22 伏两者中的较小者。

(b) 制造商推荐的充电电压大于 18 伏时，试验的最小电压应是电池最大充电电压的 1.2 倍。

Tests are to be conducted at ambient temperature. The duration of the test shall be 24 hours.

试验应在环境温度下进行。进行试验的时间应为 24 小时。

Requirement 要求

Rechargeable batteries meet this requirement if there is no disassembly and no fire during the test and within seven days after the test.

充电电池应在试验过程中和试验后 7 天内无解体，无起火。

T.8. Forced discharge 强制放电

Test method 测试方法

Each cell shall be forced discharged at ambient temperature by connecting it in series with a 12V D.C. power supply at an initial current equal to the maximum discharge current specified by the manufacturer.

每个电芯在环境温度下与 12V 直流电电源串联在起始电流等于制造商给定的最大放电电流的条件下强制放电。

The specified discharge current is to be obtained by connecting a resistive load of the appropriate size and rating in series with the test cell. Each cell is forced discharged for a time interval (in hours) equal to its rated capacity divided by the initial test current (in ampere).

试样电芯与一个适当大小的电阻负载串联以调节到规定大小的放电电流。每个电芯的放电时间(单位为 h)等于电芯的额定容量除以试验初始放电电流(单位 A)。

Requirement 要求

Primary or rechargeable cells meet this requirement if there is no disassembly and no fire during the test and within seven days after the test.

原电芯或充电电芯应在试验过程中和试验后 7 天内无解体，无起火。

V、Test Procedure 测试流程

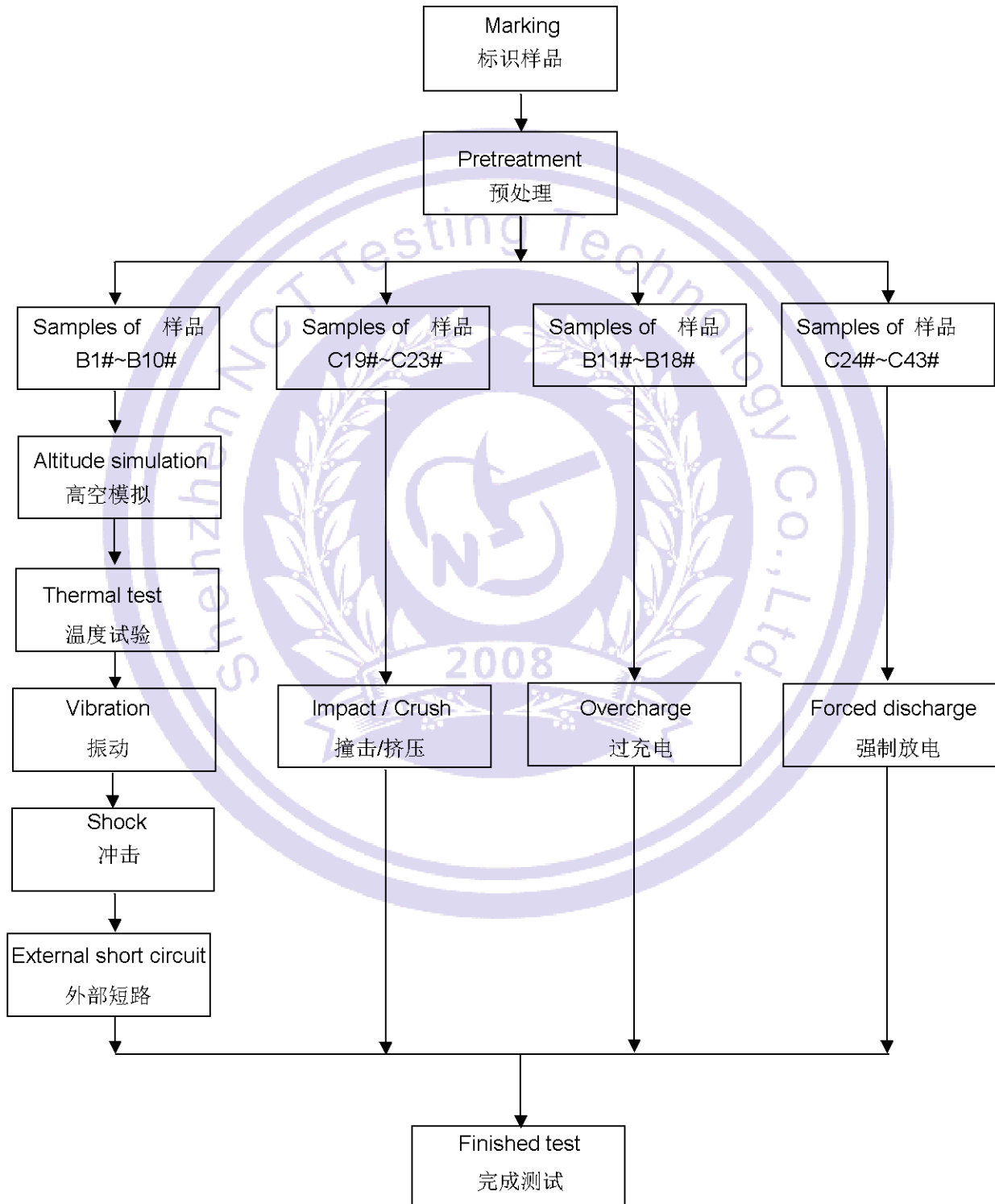

VI、Main Test Apparatus 主要测试仪器

Serial No. 设备编号	Name of Equipment 设备名称	Model 型号	Calibration Date /Due Date 校准日期/到期日
NCT-030	Charge and discharge testing system 充放电测试系统	R2D6-5V-5A	2018. 02. 03
			2019. 02. 02
NCT-012	Low-pressure high-altitude simulation test chamber 低压高空模拟试验箱	GX-3020-Z	2018. 02. 03
			2019. 02. 02
NCT-017	Constant temperature and humidity test chamber 恒温恒湿试验箱	GX-3000-150LT	2018. 02. 03
			2019. 02. 02
NCT-021	Vibration test instrument 振动测试仪器	ES-3-150	2018. 02. 03
			2019. 02. 02
NCT-022	Shock test instrument 冲击测试仪器	SY10-2	2018. 08.04
			2019. 08. 03
NCT-018	Battery short circuit test instrument 电池短路测试仪器	BE-1000W	2018. 02. 03
			2019. 02. 02
NCT-020	Crush test instrument 挤压测试仪器	BE-6045T	2018. 02. 03
			2019. 02. 02
NCT-033	DC regulated power supply 直流稳压电源	PS1540	2018. 02. 03
			2019. 02. 02
NCT-016	Battery anti-explosion chamber 电池防爆箱	GX-FB-200	--
			--
NCT-003	Electronic Scale 电子秤	JC-223S	2018. 02. 03
			2019. 02. 02
NCT-053	Electronic Scale 电子秤	JA-4100	2018. 08. 04
			2019. 09. 03
NCT-052	Digital Multimeter 数字万用表	289C	2018. 02. 03
			2019. 02. 02
NCT-029	Temperature recorder 温度记录仪	34970A	2018. 02. 03
			2019. 02. 02

VII、Test Data 测试数据

T.1. Altitude simulation 高度模拟

The state of cells 样品状态	No. 编号	Pre-test 试验前		After test 试验后		Mass loss 质量损失 (%)	Voltage after test/Voltage pre-test 试验后电压/试验前电压 (%)	Status 结果
		Mass 质量 (g)	Voltage 电压 (V)	Mass 质量 (g)	Voltage 电压 (V)			
Full charged after one cycle 一次循环后 满电状态	B1#	33.001	4.196	32.998	4.193	0.009	99.929	Pass 合格
	B2#	33.622	4.192	33.620	4.188	0.006	99.905	Pass 合格
	B3#	33.692	4.193	33.689	4.190	0.009	99.928	Pass 合格
	B4#	32.744	4.191	32.742	4.187	0.006	99.905	Pass 合格
	B5#	33.149	4.189	33.146	4.185	0.009	99.905	Pass 合格
	B6#	33.042	4.193	33.039	4.190	0.009	99.928	Pass 合格
	B7#	32.798	4.188	32.796	4.184	0.006	99.904	Pass 合格
	B8#	32.519	4.192	32.516	4.189	0.009	99.928	Pass 合格
	B9#	33.357	4.191	33.355	4.188	0.006	99.928	Pass 合格
	B10#	32.428	4.193	32.425	4.189	0.009	99.905	Pass 合格

Notes 注释: Atmospheric pressure 大气压强: 1.013×10^5 Pa, Ambient temperature 环境温度: 24.1°C
After the test, there is no leakage, no venting, no disassembly, no rupture and no fire.
测试后, 电池未渗漏、未泄气、未解体、未破裂和未起火。

T.2. Thermal test 温度试验

The state of cells 样品状态	No. 编号	Pre-test 试验前		After test 试验后		Mass loss 质量损失 (%)	Voltage after test/Voltage pre-test 试验后电压/试验前电压 (%)	Status 结果
		Mass 质量 (g)	Voltage 电压 (V)	Mass 质量 (g)	Voltage 电压 (V)			
Full charged after one cycle 一次循环后 满电状态	B1#	32.998	4.193	32.990	4.181	0.024	99.714	Pass 合格
	B2#	33.620	4.188	33.608	4.172	0.036	99.618	Pass 合格
	B3#	33.689	4.190	33.681	4.178	0.024	99.714	Pass 合格
	B4#	32.742	4.187	32.730	4.171	0.037	99.618	Pass 合格
	B5#	33.146	4.185	33.134	4.169	0.036	99.618	Pass 合格
	B6#	33.039	4.190	33.031	4.178	0.024	99.714	Pass 合格
	B7#	32.796	4.184	32.784	4.168	0.037	99.618	Pass 合格
	B8#	32.516	4.189	32.508	4.177	0.025	99.714	Pass 合格
	B9#	33.355	4.188	33.347	4.172	0.024	99.618	Pass 合格
	B10#	32.425	4.189	32.413	4.173	0.037	99.618	Pass 合格

Notes 注释: Atmospheric pressure 大气压强: 1.013×10^5 Pa, Ambient temperature 环境温度: 24.2°C
After the test, there is no leakage, no venting, no disassembly, no rupture and no fire.
测试后, 电池未渗漏、未泄气、未解体、未破裂和未起火。

T.3. Vibration 振动

The state of cells 样品状态	No. 编号	Pre-test 试验前		After test 试验后		Mass loss 质量损失 (%)	Voltage after test/Voltage pre-test 试验后电压/试验前电压 (%)	Status 结果
		Mass 质量 (g)	Voltage 电压 (V)	Mass 质量 (g)	Voltage 电压 (V)			
Full charged after one cycle 一次循环后 满电状态	B1#	32.990	4.181	32.988	4.178	0.006	99.928	Pass 合格
	B2#	33.608	4.172	33.605	4.168	0.009	99.904	Pass 合格
	B3#	33.681	4.178	33.679	4.175	0.006	99.928	Pass 合格
	B4#	32.730	4.171	32.727	4.167	0.009	99.904	Pass 合格
	B5#	33.134	4.169	33.131	4.166	0.009	99.928	Pass 合格
	B6#	33.031	4.178	33.029	4.174	0.006	99.904	Pass 合格
	B7#	32.784	4.168	32.781	4.165	0.009	99.928	Pass 合格
	B8#	32.508	4.177	32.506	4.173	0.006	99.904	Pass 合格
	B9#	33.347	4.172	33.344	4.168	0.009	99.904	Pass 合格
	B10#	32.413	4.173	32.411	4.170	0.006	99.928	Pass 合格

Notes 注释: Atmospheric pressure 大气压强: 1.013×10^5 Pa, Ambient temperature 环境温度: 24.0°C
 After the test, there is no leakage, no venting, no disassembly, no rupture and no fire.
 测试后, 电池未渗漏、未泄气、未解体、未破裂和未起火。

T.4. Shock 冲击

The state of cells 样品状态	No. 编号	Pre-test 试验前		After test 试验后		Mass loss 质量损失 (%)	Voltage after test/Voltage pre-test 试验后电压/试验前电压 (%)	Status 结果
		Mass 质量 (g)	Voltage 电压 (V)	Mass 质量 (g)	Voltage 电压 (V)			
Full charged after one cycle 一次循环后 满电状态	B1#	32.988	4.178	32.986	4.175	0.006	99.928	Pass 合格
	B2#	33.605	4.168	33.602	4.165	0.009	99.928	Pass 合格
	B3#	33.679	4.175	33.677	4.171	0.006	99.904	Pass 合格
	B4#	32.727	4.167	32.725	4.164	0.006	99.928	Pass 合格
	B5#	33.131	4.166	33.128	4.162	0.009	99.904	Pass 合格
	B6#	33.029	4.174	33.026	4.170	0.009	99.904	Pass 合格
	B7#	32.781	4.165	32.779	4.162	0.006	99.928	Pass 合格
	B8#	32.506	4.173	32.503	4.169	0.009	99.904	Pass 合格
	B9#	33.344	4.168	33.342	4.165	0.006	99.928	Pass 合格
	B10#	32.411	4.170	32.408	4.166	0.009	99.904	Pass 合格

Notes 注释: Atmospheric pressure 大气压强: 1.013×10^5 Pa, Ambient temperature 环境温度: 24.3°C
 After the test, there is no leakage, no venting, no disassembly, no rupture and no fire.
 测试后, 电池未渗漏、未泄气、未解体、未破裂和未起火。

T.5. External short circuit 外部短路

The state of cells 样品状态	No. 编号	External Peak temperature(°C) 电池表面最高温度(°C)	Status 结果
Full charged after one cycle 一次循环后满电状态	B1#	57.8	Pass 合格
	B2#	58.1	Pass 合格
	B3#	57.7	Pass 合格
	B4#	58.3	Pass 合格
	B5#	58.0	Pass 合格
	B6#	57.9	Pass 合格
	B7#	58.5	Pass 合格
	B8#	57.7	Pass 合格
	B9#	57.9	Pass 合格
	B10#	58.2	Pass 合格
Notes 注释: Atmospheric pressure 大气压强: 1.013×10^5 Pa, Ambient temperature 环境温度: 24.0°C There is no disassembly, no rupture and no fire during the test and within six hours after test. 电池在测试中和测试后 6 小时内未解体、未破裂, 未起火。			

T.6. Crush 挤压

The state of cells 样品状态	No. 编号	External Peak temperature(°C) 电池表面最高温度(°C)	Status 结果
50% charged after one cycle 一次循环后 50% 充电状态	C19#	25.9	Pass 合格
	C20#	26.1	Pass 合格
	C21#	26.2	Pass 合格
	C22#	25.8	Pass 合格
	C23#	25.9	Pass 合格
Notes 注释: Atmospheric pressure 大气压强: 1.013×10^5 Pa, Ambient temperature 环境温度: 24.5°C There is no disassembly and no fire during the test and within six hours after test. 电芯在测试中和测试后 6 小时内未解体、未起火。			

T.7. Overcharge 过充电

The state of cells 样品状态	No. 编号	Status 结果
Full charged after one cycle 一次循环后满电状态	B11#	Pass 合格
	B12#	Pass 合格
	B13#	Pass 合格
	B14#	Pass 合格

Full charged after fifty cycles 五十次循环后满电状态	B15#	Pass 合格
	B16#	Pass 合格
	B17#	Pass 合格
	B18#	Pass 合格

Notes 注释: Atmospheric pressure 大气压强: 1.013×10^5 Pa, Ambient temperature 环境温度: 24.4°C
There is no disassembly and no fire during the test and within seven days after the test.
电池在测试中和测试后 7 天内未解体, 未起火。

T.8. Forced discharge 强制放电

The state of cells 样品状态	No. 编号	Status 结果
Full discharged after one cycle 一次循环完全放电状态	C24#	Pass 合格
	C25#	Pass 合格
	C26#	Pass 合格
	C27#	Pass 合格
	C28#	Pass 合格
	C29#	Pass 合格
	C30#	Pass 合格
	C31#	Pass 合格
	C32#	Pass 合格
	C33#	Pass 合格
Full discharged after fifty cycles 五十次循环完全放电状态	C34#	Pass 合格
	C35#	Pass 合格
	C36#	Pass 合格
	C37#	Pass 合格
	C38#	Pass 合格
	C39#	Pass 合格
	C40#	Pass 合格
	C41#	Pass 合格
	C42#	Pass 合格
	C43#	Pass 合格

Notes 注释: Atmospheric pressure 大气压强: 1.013×10^5 Pa, Ambient temperature 环境温度: 24.3°C
There is no disassembly and no fire during the test and within seven days after the test.
电芯在测试中和测试后 7 天内未解体, 未起火。

VIII、Conclusion 结论

No. 编号	Test item 测试项目	Sample number 样品数量	Test reference 测试参考	Conclusion 结论	
1	Altitude simulation 高空模拟	B1#~B10#	UN Manual of Test and Criteria, part III, subsection 38.3.4.1 UN 试验和标准手册,第III部分,第 38.3.4.1 节	Pass 合格	
2	Thermal test 温度试验		UN Manual of Test and Criteria, part III, subsection 38.3.4.2 UN 试验和标准手册,第III部分,第 38.3.4.2 节	Pass 合格	
3	Vibration 振动		UN Manual of Test and Criteria, part III, subsection 38.3.4.3 UN 试验和标准手册,第III部分,第 38.3.4.3 节	Pass 合格	
4	Shock 冲击		UN Manual of Test and Criteria, part III, subsection 38.3.4.4 UN 试验和标准手册,第III部分,第 38.3.4.4 节	Pass 合格	
5	External short circuit 外部短路		UN Manual of Test and Criteria, part III, subsection 38.3.4.5 UN 试验和标准手册,第III部分,第 38.3.4.5 节	Pass 合格	
6	Impact/Crush 撞击/挤压		C19#~C23#	UN Manual of Test and Criteria, part III, subsection 38.3.4.6 UN 试验和标准手册,第III部分,第 38.3.4.6 节	Pass 合格
7	Overcharge 过度充电		B11#~B18#	UN Manual of Test and Criteria, part III, subsection 38.3.4.7 UN 试验和标准手册,第III部分,第 38.3.4.7 节	Pass 合格
8	Forced discharge 强制放电		C24#~C43#	UN Manual of Test and Criteria, part III, subsection 38.3.4.8 UN 试验和标准手册,第III部分,第 38.3.4.8 节	Pass 合格

The submitted samples were complied with the stated requirements of UN manual of test and criteria, part III, subsection 38.3

经检测,提交的测试样品均符合 UN38.3 的要求,测试结论为合格。

IX、Photo of The Sample 样品图片

Model 型号: PL804050

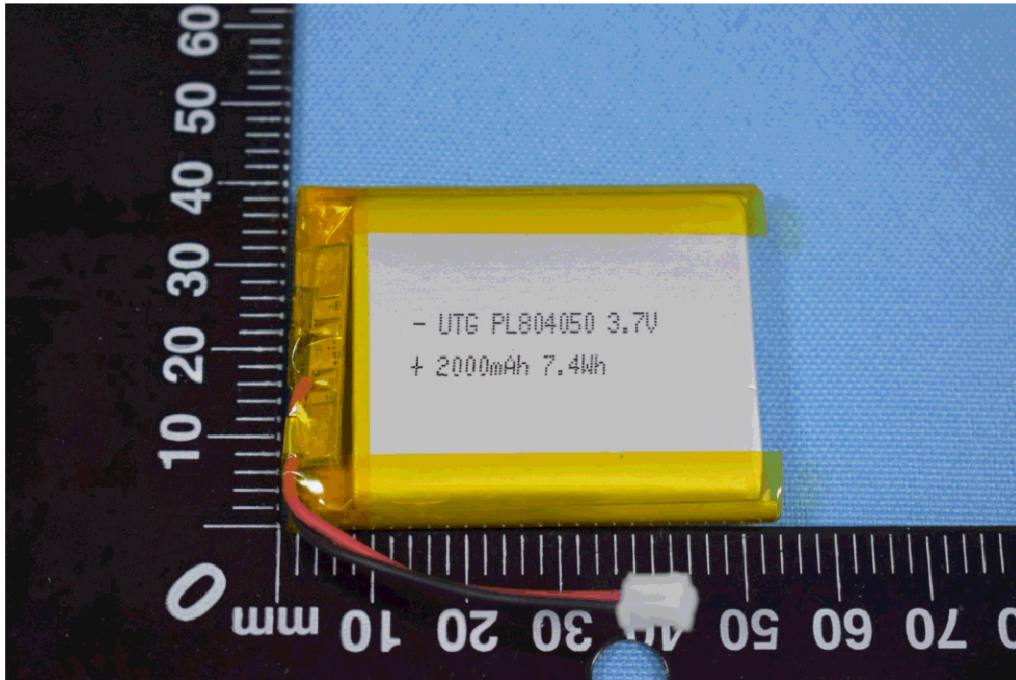

Photo 1 Front 正面

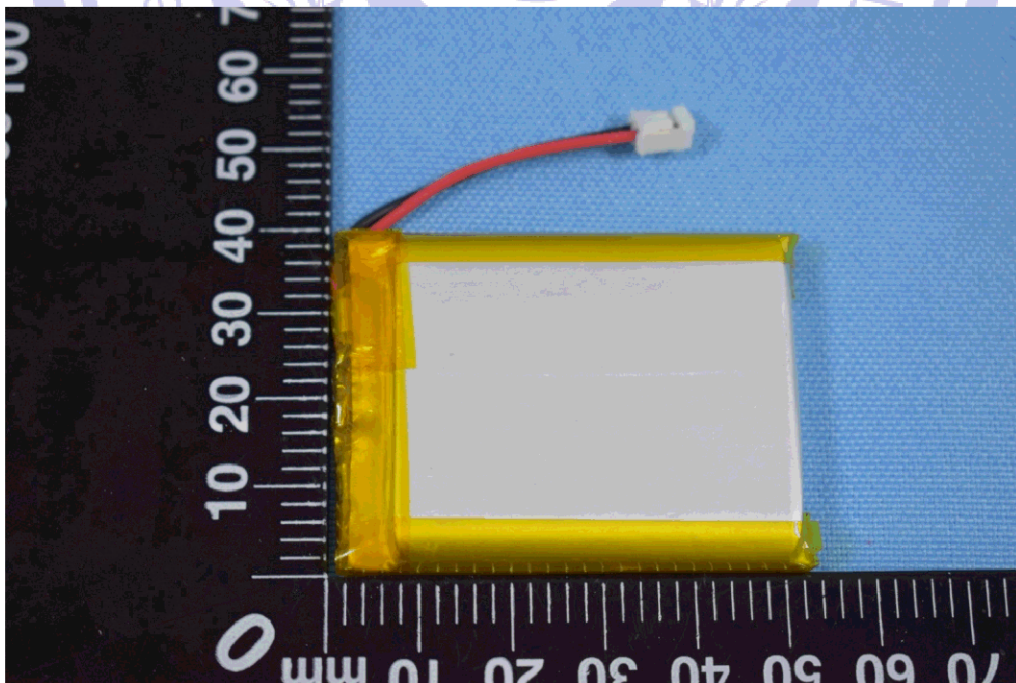

Photo 2 Rear 反面

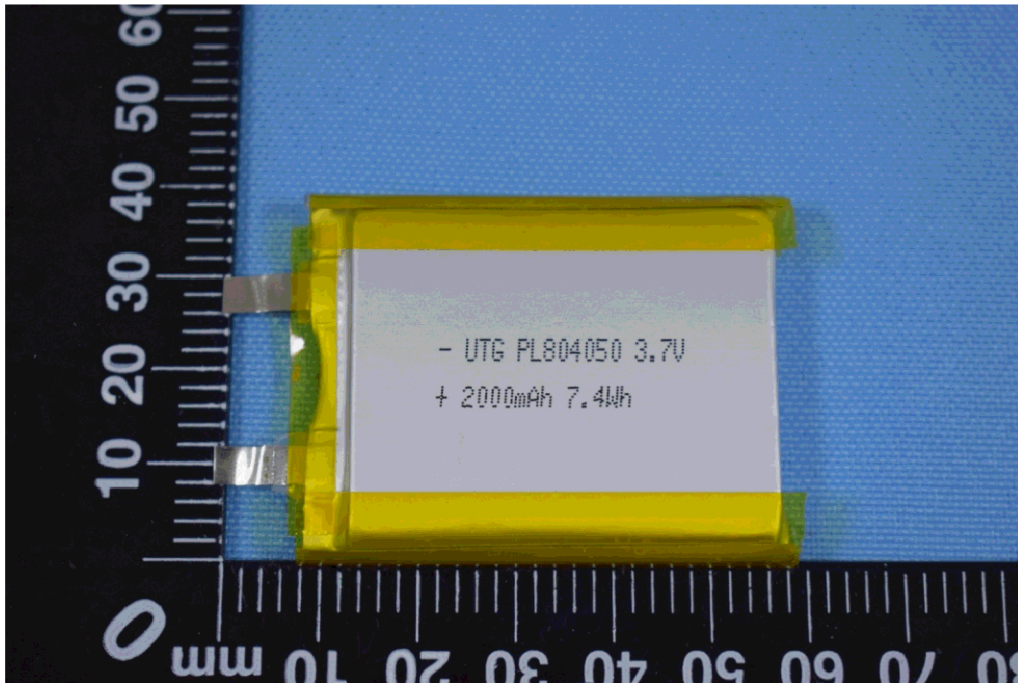

Photo 3 Internal Cell 内部电芯

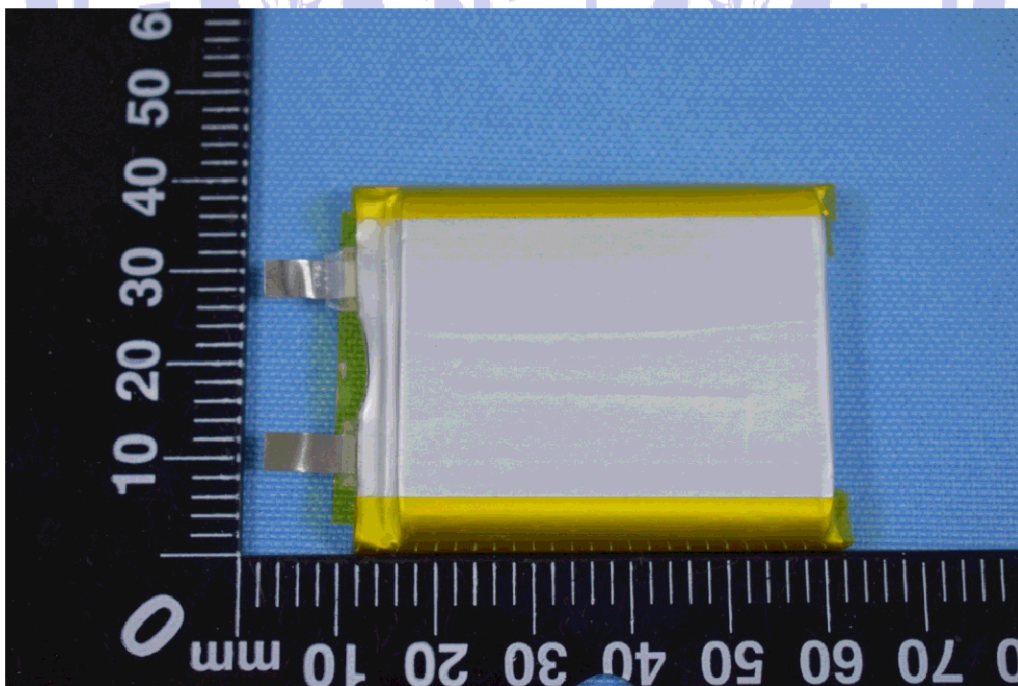

Photo 4 Internal Cell 内部电芯

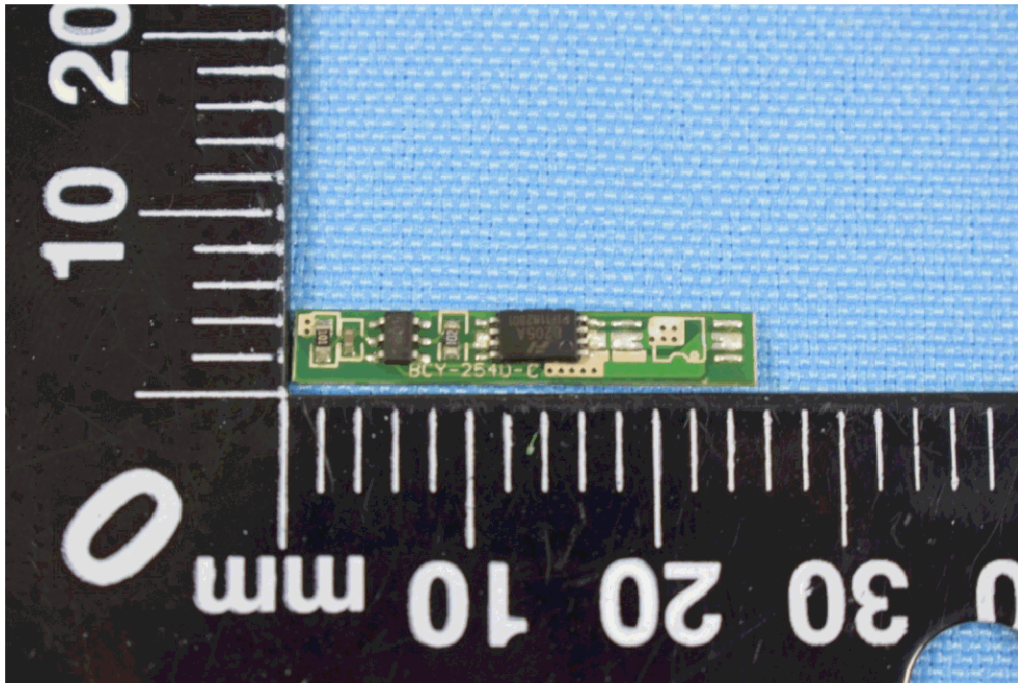

Photo 5 Protection board 保护板

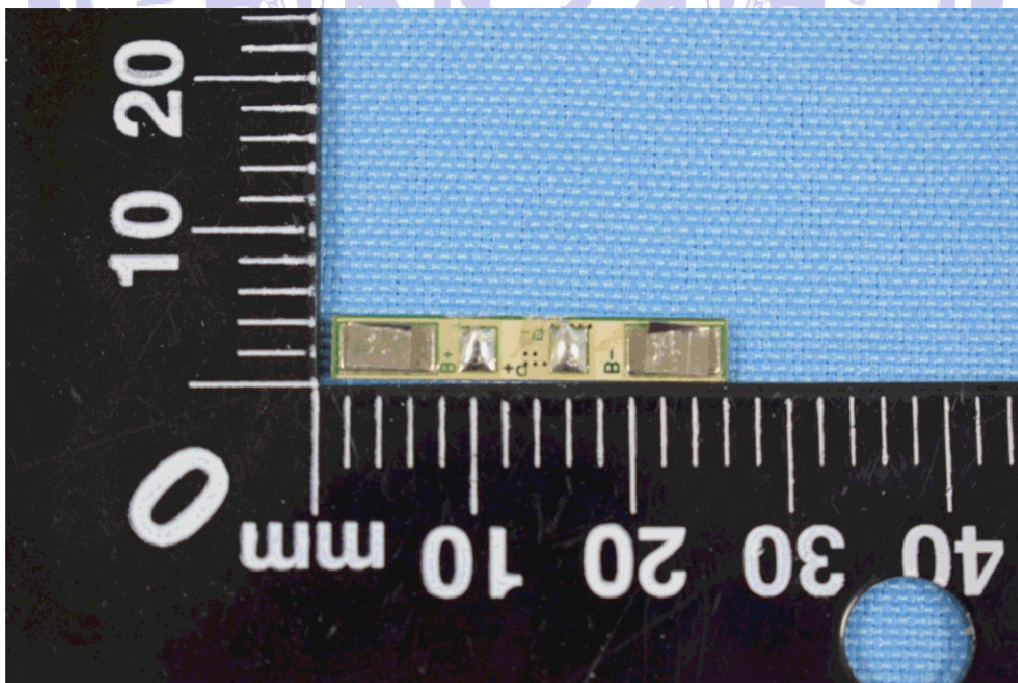

Photo 6 Protection board 保护板

注意事项**Important Notice**

1. The test report is invalid without the official stamp of NCT.
本报告书无 NCT 盖章无效。
2. Nobody is allowed to photocopy or partly photocopy this test report without written permission of NCT.
未经 NCT 书面同意，不得复制或部分地复制本报告书。
3. The test report is invalid without the signatures of Ratifier, Reviewer and Testing engineer.
本报告书无批准人、审核人、及主检人签名无效。
4. The report is invalid when anything of following happens – illegal transfer, reproduce, embezzlement, imposture, modification or tampering in any media form.
私自转让、复制、盗用、冒用、涂改、或以任何媒体形式篡改的报告书无效。
5. Objections to the test report must be submitted to NCT within 15 days.
对报告书若有异议，应于收到报告之日起 15 天内向本公司提出。
6. The test report is valid for the tested samples only.
本报告仅对测试样品有效。
7. The Chinese contents in this report are only for reference.
本报告中的中文内容仅供参考。

*****End of Report 报告结束*****

Material Safety Data Sheet

化学品安全技术说明书

Section 1- Chemical Product & Company Identification

第一部分 化学品及企业标识

Product Name: Polymer Lithium-ion Battery

产品名称: 聚合物锂离子电池

Manufacture: Shenzhen Yotoga Technology Co., Ltd

制造商: 深圳市优特佳科技有限公司

Address: 4th, Block C11, Xinan No. 2 Industry Zone, No.2 Gushu Road, Xixiang Town, Baoan District, Shenzhen

地址: 深圳市宝安区西乡固戍二路新安第二工业区 C11 栋 4 楼

Contact Person 联系人: Bora wang

Tel 电话: +86-755-29238051

Fax 传真: +86-755-29238132

Emergency Tel 应急电话: +86-755-29238051

E-mail 邮箱: wx@yotoga.cn

Item Code 项目号: NCT19010054XM1-1

Section 2- Hazards Identification

第二部分 危险性概述

Hazard Description 危险性描述	Not dangerous with normal use. Do not dismantle, open or shred the battery ingredients contained within or their ingredients products could be harmful. 正常使用没有危险, 不能拆解、打开或分解电池, 里面的材料或成分是有毒的。
Primary	Inhalation, Ingestion, Skin contact and Eye contact.

Route(s) of Exposure 接触途径	吸入、食入、皮肤接触、眼睛接触。
Potential Health Effects 潜在健康影响	<p>Inhalation: Vapors or mists from a ruptured battery may cause respiratory irritation. 吸入：破裂的电池散发出来的气雾会引起呼吸道刺激。</p> <p>Ingestion: The battery ingredients contained within or their ingredients products can cause serious chemical burns of mouth, esophagus, and gastrointestinal tract. 食入：电池的组成成分或原料可以导致嘴，食道和胃肠道的严重化学烧伤。</p> <p>Skin: Skin contact with contents of an open battery can cause severe irritation or burns to the skin. 皮肤：皮肤接触到电池的内部化学材料可能会导致严重的刺激或烧伤皮肤。</p> <p>Eye: Eye contact with contents of an open battery can cause severe irritation or burns to the eye. 眼睛：眼睛接触到电池的内部化学材料可能会导致严重的刺激或烧伤眼睛。</p>

Section 3- Composition/Information on Ingredients

第三部分 成分/组成信息

Chemical Name 化学名称	Concentration or concentration ranges (%) 浓度或浓度范围(%)	CAS Number CAS 号 (化学文摘索引登记号)
Lithium Cobalt Oxide 钴酸锂	35-38	12190-79-3
Graphite 石墨	20-22	7782-42-5
Copper 铜	9-10	7440-50-8
Aluminum 铝	5-6	7429-90-5
Ethylene carbonate 碳酸乙烯酯	14-16	96-49-1
Polypropylene 聚丙烯	5-6	9003-07-0
Carbonate, methyl ethyl 碳酸甲乙酯	4-5	623-53-0
Phosphate(1-), hexafluoro-, lithium 六氟磷酸锂	5-6	21324-40-3

Note: CAS number is Chemical Abstract Service Registry Number.

注意：CAS 号是化学文摘服务注册号。

N/A=Not apply.

N/A =不适用。

Section 4- First Aid Measures

第四部分 急救措施

Inhalation 吸入	Remove source of contamination or move victim to fresh air. Obtain medical advice. 移除污染源或者将受害者移至新鲜空气处。寻求医生建议。
Ingestion 食入	Please rinse mouth thoroughly with water. Induce vomiting under the guidance of professional personage. Please seek medical treatment in time. 立即用清水漱口，在专业人士的指导下催吐，速就医。
Skin contact 皮肤接触	Remove contaminated clothes and rinse skin with plenty of water or shower for 15 minutes. Get medical aid. 脱下已污染衣服，用大量的水冲洗至少 15 分钟，速就医。
Eye contact 眼睛接触	Irrigate with flowing water for 15 minutes. If irritation persists, consult a physician. 用流动水冲洗 15 分钟，如刺激持续发生，请求助于医生。

Section 5- Fire Fighting Measures

第五部分 消防措施

Characteristics of Hazard 危险特性	Toxic fumes, gases or vapors may evolve on burning. 火灾时可释放有害浓烟、气体或者蒸汽。
Hazardous Combustion Products 燃烧产生的危险物品	Carbon monoxide, carbon dioxide, lithium oxide fumes and so on. 一氧化碳，二氧化碳，锂氧化物烟气等。
Fire-extinguishing Methods and Extinguishing Media 灭火方法及灭火剂	Please use dry powder fire extinguisher and other proper fire extinguishing media. 请使用干粉灭火器等合适的灭火介质。
Attention in Fire-extinguishing 灭火注意事项	The firemen should put on antigas masks and full fire-fighting suits. 消防人员须佩戴防毒面具、穿全身消防服。

Section 6- Accidental Release Measures

第六部分 泄露应急处理

<p>Personal Precautions, protective equipment, and emergency procedures 个人预防措施、防护装备和应急程序</p>	<p>Restrict access to area until completion of clean-up. Do not touch the spilled material. Wear adequate personal protective equipment as indicated in Section 8. 限制区域，直到完成清理工作。请勿触摸泄漏的材料。穿戴适当的个人防护设备，如第 8 部分所示。</p>
<p>Environmental Precautions 环境保护措施</p>	<p>Prevent material from contaminating soil and from entering sewers or waterways. 防止物质污染土壤和进入下水道或水道。</p>
<p>Methods and materials for Containment 方法和材料控制</p>	<p>Stop the leak if safe to do so. Contain the spilled liquid with dry sand or earth. Clean up spills immediately. 出于安全，阻止泄漏，可以用干砂或沙土来遏制液体泄露，立即清理泄漏。</p>
<p>Methods and materials for cleaning up 清理的方法和材料</p>	<p>Absorb spilled material with an inert absorbent (dry sand or earth). Scoop contaminated absorbent into an acceptable waste container. Collect all contaminated absorbent and dispose of according to directions in Section 13. Scrub the area with detergent and water; collect all contaminated wash water for proper disposal. 用惰性吸收剂(干砂或沙土)吸收溢出的材料。污染物转移到可吸收废物的容器。收集所有受污染的吸收剂和根据第 13 部分的指令处置。用洗涤剂和水清洁污染区域,收集所有受污染的洗涤水进行适当处置。</p>

Section 7- Handling and Storage

第七部分 操作处置与储存

<p>Handling 操作</p>	<p>Don't handling the batteries in manner that allows terminals to short circuit. Do not open, disassemble, crush or burn battery. 不要以让接头短路的方式对电池进行操作。不要打开，分解，挤压或燃烧电池。</p>
<p>Storage 储存</p>	<p>If the battery is subject to storage for such a long term as more than 3 months, it is recommended to recharge the battery periodically. 如果电池长期存放超过 3 个月，建议定期对电池充电。 And recommended at -5°C~+45°C for long period storage. 并建议长期储存温度在：-5°C~+45°C。 Do not storage the battery haphazardly in a box or drawer where they may short-circuit each other or be short-circuited by other metal objects. 不要将电池随意丢在盒子或抽屉里，以免电池之间或电池与其他金属物质发生短路。 Keep out of reach of children.</p>

储存在小孩接触不到的地方。
 Do not expose the battery to heat or fire. Avoid storage in direct sunlight.
 不要将电池暴露在火源和热源附近，避免在阳光直射下存储。
 Do not store together with oxidizing and acidic materials.
 不要与氧化和酸性物质存储在一起。

Section 8 - Exposure Controls/Personal Protection

第八部分 接触控制和个体防护

<p>Engineering Controls 工程控制</p>	<p>No engineering controls are required for handling batteries that have not been damaged. Personal protective equipments for damaged batteries should include chemical resistant gloves and safety glasses. 操作未破损的电池，没有工程控制要求。对于破损的电池，个人防护用品应包括化学品防护手套和安全眼镜。</p>
<p>Personal Protective Equipment 个人防护设备</p>	<p>Respiratory Protection: In case of battery venting, provide as much ventilation as possible. Avoid confined areas with venting cell cores. Respiratory Protection is not necessary under conditions of normal use. Not necessary under conditions of normal use. 呼吸保护：当电池排气阀打开时，应尽量使通风设备开至最大，避免将打开排气阀的电芯局限在某一狭窄空间内。正常操作条件下，呼吸保护是不必要的。正常使用条件下不必考虑。</p> <p>Protective Gloves: Not necessary under conditions of normal use. 防护手套：正常使用条件下不必考虑。</p> <p>Other Protective Clothing or Equipment: Not necessary under conditions of normal use. 其他防护服装或设备：正常使用条件下不必考虑。</p> <p>Personal Protection is recommended for venting battery: Respiratory Protection, Protective Gloves, Protective Clothing and safety glass with side shields. 当电池排气阀打开时，应做好个人防护：呼吸防护，防护手套，防护服装和有护边的安全玻璃罩都是要准备的。</p>

Section 9- Physical and Chemical Properties

第九部分 理化特性

<p>Physical State 物理状态</p>	<p>Form: Solid 形态：固体</p>
	<p>Color: Silver 颜色：银色</p>

	<p>Odour: Odorless 气味: 无气味</p>
<p>Change in condition 变化条件:</p>	
<p>pH, with indication of the concentration pH, 有浓度指示</p>	<p>Not applicable. 不适用</p>
<p>Melting point/freezing point 熔点/凝固点</p>	<p>Not applicable. 不适用</p>
<p>Boiling Point, initial boiling point 沸点, 初沸点</p>	<p>Not applicable. 不适用</p>
<p>Flash Point 闪点</p>	<p>Not applicable. 不适用</p>
<p>Upper/lower flammability or explosive limits 上/下燃烧或爆炸限值</p>	<p>Not applicable. 不适用</p>
<p>Vapor Pressure 蒸汽压</p>	<p>Not applicable. 不适用</p>
<p>Vapor Density: (Air = 1) 蒸汽密度: (空气= 1)</p>	<p>Not applicable. 不适用</p>
<p>Density/relative density 密度/相对密度</p>	<p>Not applicable. 不适用</p>
<p>Solubility in Water 水溶性</p>	<p>Insoluble 不能溶解</p>
<p>n-octanol/water partition coefficient 正辛醇/水分配系数</p>	<p>Not applicable. 不适用</p>
<p>Auto-ignition temperature 自燃温度</p>	<p>Not applicable. 不适用</p>
<p>Decomposition temperature 分解温度</p>	<p>Not applicable. 不适用</p>
<p>Odour threshold 溴阈</p>	<p>Not applicable. 不适用</p>

Evaporation rate 蒸发速率	Not applicable. 不适用
Flammability (soil, gas) 易燃性 (土壤, 气体)	Not applicable. 不适用
Viscosity 粘度	Not applicable. 不适用

Section 10 – Stability and Reactivity

第十部分 稳定性和反应性

Stability 稳定性	Stable under normal temperatures and pressures. 常温常压下稳定。
Conditions to Avoid 应避免的条件	Heat above 70°C or Incinerate, Deform, Mutilate, Crush, Disassemble, Overcharge, Short circuit, Expose over a long period to humid conditions. 加热 70°C 以上或焚烧、变形、毁坏、粉碎、拆卸、过充电、短路, 长时间暴露在潮湿的条件下。
Hazardous Decomposition Products 危害分解物	Toxic Fumes, and may form peroxides. 有毒烟雾, 并可能形成过氧化物。
Possibility of Hazardous Reaction 危险反应的可能性	If leaked, forbidden to contact with strong oxidizers, mineral acids, strong alkalis, halogenated hydrocarbons. 如果发生泄露, 避免与强氧化剂, 无机酸, 强碱, 卤代烃接触。

Section 11 – Toxicological Information

第十一部分 毒理学信息

Irritation 刺激	In the event of exposure to internal contents, vapor fumes may be very irritating to the eyes and skin. 内部物质暴露的情况下, 蒸汽烟雾可能对眼睛和皮肤产生刺激性。
Sensitization 致敏	Not applicable. 不适用
Reproductive Toxicity 再生毒性	Not applicable. 不适用
Toxicologically Synergistic	Not applicable.

Materials 协同材料毒理学	不适用
-----------------------------	-----

Section 12-Ecological Information

第十二部分 生态学信息

General note 通用信息	Do not allow undiluted product or large quantities of it to reach ground water, water course or sewage system. 不允许未稀释或大量的产品到达地下水、水道或污水系统。
Anticipated behavior of a chemical product in environment/possible environmental impact/ecotoxicity 化学产品对环境/可能的环境预期的行为的一种生态毒性	Not applicable. 不适用
Mobility in soil 土壤中移动性	Not applicable. 不适用
Persistence and Degradability 持久性和降解性	Not applicable. 不适用

Section 13 – Disposal Considerations

第十三部分 废弃处置

Waste Treatment 废弃处置方法	Recycle or dispose of in accordance with government, state & local regulations. 建议遵照国家和地方法规处置或再利用。
Attention for Waste Treatment 废弃注意事项	Deserted batteries couldn't be treated as ordinary trash. Couldn't be thrown into fire or placed in high temperature. Couldn't be dissected, pierced, crushed or treated similarly. Best way is recycling. 废电池不能被当做普通垃圾。不能扔进火中或置于高温下。不能解体，刺穿，破碎或类似的处理。最好的办法是回收利用。

Section 14 – Transport Information

第十四部分 运输信息

This report applies to by sea, by air and by land;

本报告适用于海运，空运和陆运

The Polymer Lithium-ion Battery (model: PL804050) tested according to the requirements of the UNITED NATIONS "Recommendations on the Transport of Dangerous Goods, Manual of Tests and Criteria" Part III, subsection 38.3;

该聚合物锂离子电池（型号：PL804050）经过测试符合联合国《关于危险货物运输的建议书 实验和标准手册》第三部分，第 38.3 章节的要求。

The Polymer Lithium-ion Battery was protected so as to prevent short circuits. This includes protection against contact with conductive materials within the same packaging that could lead to short circuit;

该聚合物锂离子电池做了防短路保护。包括防止与同一封装内的导电材料接触可能导致的短路。

The packaging shall be adequate to avoid mechanical damage during transport, handling and stacking.

包装应足以避免在运输，处理和堆放期间的机械损坏。

The package must be handled with care and that a flammability hazard exists if the package is damaged.

包装必须小心处理，如果包装损坏，存在易燃危险。

The Polymer Lithium-ion Battery can be shipped by air in according to Section II/Section IB of PACKING INSTRUCTION 965, or Section II of PACKING INSTRUCTION 966~967 of the 2019 IATA Dangerous Goods regulations 60th Edition.

该聚合物锂离子电池可以根据 2019 年 IATA 危险物品规则第 60 版包装指令 965 第 II 部分/第 IB 部分或包装指令 966~967 第 II 部分运输。

With regard to transport, the following regulations are cited and considered:

关于运输，引用和考虑了以下法规：

- The International Civil Aviation Organization (ICAO) Technical Instructions.
- 国际民用航空组织（ICAO）技术细则。
- The International Air transport Association (IATA) Dangerous Goods Regulations.
- 国际航空运输协会（IATA）危险物品规则。

UN number of lithium battery: UN3480 or UN3481;

锂电池的 UN 编号：UN3480 或 UN3481；

UN Proper shipping name/Description (technical name): Lithium ion batteries or Lithium ion batteries contained in equipment or Lithium ion batteries packed with equipment;

UN 合适的运输名称/描述（技术名称）：锂离子电池，锂离子电池内置于设备中或锂离子电池与设备包装在一起；

UN Classification (Transport hazard class): Class 9 (PI965 Section IB) or N/A (PI965~967 Section II)

UN 分类（运输危险类别）：9 类危险品（包装指令 965 第 IB 部分）或者 不适用（包装指令 965~967 第 II 部分）

- The International Maritime Dangerous Goods (IMDG) Code.

- 国际海运危险货物（IMDG）规则。

UN number of lithium battery: UN3480 or UN3481;

锂电池的 UN 编号：UN3480 或 UN3481；

UN Proper shipping name/Description (technical name): Lithium ion batteries or Lithium ion batteries contained in equipment or Lithium ion batteries packed with equipment;

UN 合适的运输名称/描述 (技术名称): 锂离子电池, 锂离子电池内置于设备中或锂离子电池与设备包装在一起;

UN Classification (Transport hazard class): N/A

UN 分类 (运输危险类别): 不适用

Marine pollutant(Y/N): N

海洋污染物 (Y/N): N

The battery is not restricted according to IMO IMDG Code (inc Amdt 39-18).

海运按照 IMO IMDG Code (inc Amdt 39-18) 可按普通货物条件办理。

Need to meet the Special Provision: International maritime dangerous goods code (IMDG) 188, 230, 310, 348, 957;

需要符合这些特殊条款: 国际海运危险货物规则 (IMDG) 188, 230, 310, 348, 957;

Section 15 – Regulatory Information

第十五部分 法规信息

《Dangerous Goods Regulations》

《危险物品规则》

《Recommendations on the Transport of Dangerous Goods Model Regulations》

《危险货物运输的建议模型规定》

《International Maritime Dangerous Goods》

《国际海上危险货物运输》

《Technical Instructions for the Safe Transport of Dangerous Goods》

《危险货物安全运输技术指南》

《Classification and code of dangerous goods 》 2008

《危险货物分类与代码》

《Occupational Safety and Health Act 》 (OSHA)

《职业安全与健康法案》 (OSHA)

《Toxic Substance Control Act》 (TSCA)

《有毒物质控制法》 (TSCA)

《Consumer Product Safety Act 》 (CPSA)

《消费者产品安全法案》 (CPSA)

《Federal Environmental Pollution Control Act》 (FEPCA)

《联邦环境污染控制法》 (FEPCA)

《The Oil Pollution Act》 (OPA)

《石油污染法》 (OPA)

《Superfund Amendments and Reauthorization Act TitleIII(302/311/312/313) 》 (SARA) 《超级基金修正案和再授权法案 TitleIII(302/311/312/313)》 (SARA)

《Resource Conservation and Recovery Act》 (RCRA)

《资源保护和恢复法案》(RCRA)

《Safety Drinking Water Act》(CWA)

《安全饮用水法》(CWA)

《California Proposition 65》

《加州 65 号提案》

《Code of Federal Regulations》(CFR)

《联邦条例》(CFR)

In accordance with all Federal, State and local laws.

符合所有联邦、州和地方法律。

Section 16 – Additional Information

第十六部分 其他信息

The information above is believed to be accurate and represents the best information currently available to us. However, we makes no warranty of merchantability or any other warranty, express or implied, with respect to such information, and we assume no liability resulting from its use. Users should make their own investigations to determine the suitability of the information for their particular purposes. Although reasonable precautions have been taken in the preparation of the data contained herein, it is offered solely for your information, consideration and investigation. This material safety data sheet provides guidelines for the safe handling and use of this product; it does not and cannot advise on all possible situations, therefore, your specific use of this product should be evaluated to determine if additional precautions are required.

The data/information contained herein has been reviewed and approved for general release on the basis that this document contains no export controlled information.

在我们看来上面的信息是准确的，这是我们目前能提供的最佳的信息。但是，对于这些信息，我们不对商品的性能做任何明示的或者暗示的保证，我们也不对使用这些信息造成的后果担负任何责任。用户应当自己调查研究后决定这些信息是否适用于他们的特定用途。尽管在该文档里提出了合理的预警，但是这仅仅只是给您做参考，考量和调查。这份化学品安全技术说明书提供了安全处理和使用该产品的指南，但是它没有，也不能对所有可能发生的情景提出建议，所以您需要根据您对该产品的特定使用情况来决定是否需要其他的预防措施。

此处所包含的数据/信息作为普通版本已经审核并批准，但是本文档不包含出口控制信息。

*******End of report 报告结束*******

1.2M 跌落测试报告

1.2M Drop Test Report

Client 委托方	Shenzhen Yotoga Technology Co., Ltd 深圳市优特佳科技有限公司
Add. of Client 委托方地址	4th, Block C11, Xinan No. 2 Industry Zone, No.2 Gushu Road, Xixiang Town, Baoan District, Shenzhen 深圳市宝安区西乡固戍二路新安第二工业区 C11 栋 4 楼
Samples Description 样品名称	Polymer Lithium-ion Battery 聚合物锂离子电池
Model/Type 型号规格	PL804050
Testing Laboratory 测试机构	Shenzhen NCT Testing Technology Co., Ltd. 深圳诺测检测技术有限公司 1 / F, No. B Building, Mianshang Younger Pioneer Park, Hangcheng Road, Gushu Xixiang Street, Baoan District, Shenzhen, Guangdong, China 中国广东省深圳市宝安区西乡街道固戍航城大道绵商青年创业园 B 栋第 1 层
Report No. 报告编号	NCT18043212B1-2
Issued Date 发行日期	Nov. 26, 2018
Test Conclusion 测试结论: Shown in the Conclusion of test report. 见检测报告结论页.	

Tested by 主检人: Bowre Lin

Approved by 批准人: _____

Inspected by 审核人: Hely Wang

Seal of NCT 报告单位 (盖章)

Date of Issue 签发日期: _____

2018. 11. 26



I、SAMPLE DESCRIPTION 样品描述

Product Name 产品名称	Polymer Lithium-ion Battery 聚合物锂离子电池		Sample Model 样品型号	PL804050	
Manufacturer 制造商	Shenzhen Yotoga Technology Co., Ltd 深圳市优特佳科技有限公司				
Address 地址	4th, Block C11, Xinan No. 2 Industry Zone, No.2 Gushu Road, Xixiang Town, Baoan District, Shenzhen 深圳市宝安区西乡固戍二路新安第二工业区 C11 栋 4 楼				
Trade Mark 商标	---	Cell Shape 电芯形状	Prismatic 棱柱形	Packaging dimensions 包装尺寸 (L×W×T)	(340×270×120)mm
Nominal Voltage 标称电压	3.7V	Rated Capacity 额定容量	2000mAh 7.4Wh	Battery Number 电池数量	60/PCS
Gross weight per package 每包装件毛重	3kg		Net weight of batteries per package 每包装件锂离子电池的净重	1.92kg/packing	
Receiving Date 接收日期	Nov. 24, 2018		Completing Date 完成日期	Nov. 26, 2018	

II、STANDARD 标准

UNITED NATIONS "Recommendations on the TRANSPORT OF DANGEROUS GOODS" Model Regulations (19th) special provisions 188

联合国《关于危险货物运输的建议书 规范章节》(Rev.19)特殊规定 188 条款

Section IB of Packing Instructions 965 of 59th DGR Manual of IATA.

IATA《危险品规则》(59 版) 包装说明 965 第 IB 章节。

Special provision 188 of INTERNATIONAL MARITIME DANGEROUS GOODS CODE (Amdt.38-16)

IMO《国际海运危险货物规则》(38-16 版) 特殊规定 188 条款。

III、TEST ITEM 测试项目

- 1). Drop test 跌落测试
- 2). Packing weight test 包装重量测试

IV、TEST METHOD 测试方法

The package of batteries is dropped from 1.2m, 5times per package. The test floor is concrete floor, each package is capable of withstanding a 1.2 meter drop test in any orientation without damage to cell or batteries contained therein. Without shifting of the contents so as to allow battery to battery (or cell to cell) contact and without release of contents.

电池包装件(或含有电池的包装件)从 1.2 米高度进行跌落,每个包装件 5 次.测试底板为混凝土底板,每一个包装件应能承受在任一方位的 1.2 米跌落测试,并且没有电芯或电池损坏.没有位移导致电池或电芯相互接触,并没有内部物品从箱体漏出。

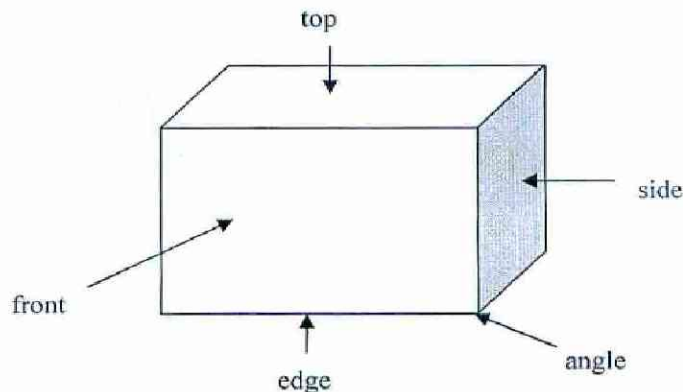

V、TEST APPARATUS 测试仪器

Serial No. 设备编号	Name of Equipment 设备名称	Model 型号	Calibration Date /Due Date 校准日期/到期日
NCT-013	Drop test instrument 跌落测试仪器	GX-6050-A	2018. 02. 03
			2019. 02. 02
NCT-070	Electronic scale 电子秤	ACS-T	2018. 02. 03
			2019. 02. 02

VI、TEST RESULT 测试结果

1) Drop test 跌落测试

Drop position 跌落位置	Test status 测试情况	Conclusion 结论
Front 前面	Without damage packaging 包装没有损坏	Pass 合格
Bottom 底部	Without damage packaging 包装没有损坏	Pass 合格
Angle 角	Without damage packaging 包装没有损坏	Pass 合格

Side 侧面	Without damage packaging 包装没有损坏	Pass 合格
Top 顶部	Without damage packaging 包装没有损坏	Pass 合格

2) Packing weight test 包装重量测试

No. 编号	Test item 测试项目	Weight 重量 (kg)	Remark 备注
1	Packing weight test 包装重量测试	3	---

Photos 照片

Samples 样品:

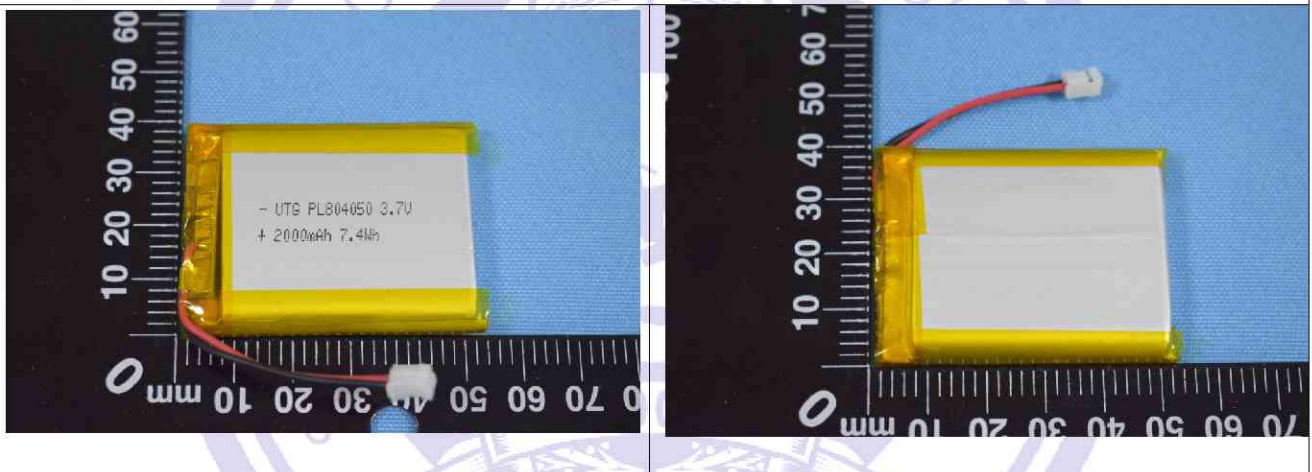

Package 包装: (空运)



Package 包装: (海运)



注意事项

Important Notice

1. The test report is invalid without the official stamp of NCT.
本报告书无 NCT 盖章无效。
2. Nobody is allowed to photocopy or partly photocopy this test report without written permission of NCT.
未经 NCT 书面同意，不得部分地复制本报告书。
3. The test report is invalid without the signatures of Ratifier, Reviewer and Testing engineer.
本报告书无批准人、审核人、及主检人签名无效。
4. The report is invalid when anything of following happens – illegal transfer, reproduce, embezzlement, imposture, modification or tampering in any media form.
私自转让、复制、盗用、冒用、涂改、或以任何媒体形式篡改的报告书无效。
5. Objections to the test report must be submitted to TCT within 15 days.
对报告书若有异议，应于收到报告之日起 15 天内向本公司提出。
6. The test report is valid for the tested samples only.
本报告仅对测试样品有效。
7. The Chinese contents in this report are only for reference.
本报告中的中文内容仅供参考。

*****End of Report 报告结束*****

货物运输条件鉴定报告书

Report for Safe Transport of Goods



货物名称: 聚合物锂离子电池 PL804050
Name of Goods: Polymer Lithium-ion Battery PL804050
委托单位: 深圳市优特佳科技有限公司
Commission by: Shenzhen Yotoga Technology Co., Ltd
运输方式: 海运
Transportation: Marine

深圳诺测检测技术有限公司
Shenzhen NCT Testing Technology Co., Ltd.

货物运输条件鉴定报告书
Report for Safe Transport of Goods

样品名称 Name of Goods	聚合物锂离子电池 Polymer Lithium-ion Battery
样品型号 Type/Mode	PL804050
委托单位 Commissioned by	深圳市优特佳科技有限公司 Shenzhen Yotoga Technology Co., Ltd
委托单位地址 Commissioner address	深圳市宝安区西乡固戍二路新安第二工业区 C11 栋 4 楼 4th, Block C11, Xinan No. 2 Industry Zone, No.2 Gushu Road, Xixiang Town, Baoan District, Shenzhen
制造商 Manufacturer	深圳市优特佳科技有限公司 Shenzhen Yotoga Technology Co., Ltd
制造商地址 Manufacturer address	深圳市宝安区西乡固戍二路新安第二工业区 C11 栋 4 楼 4th, Block C11, Xinan No. 2 Industry Zone, No.2 Gushu Road, Xixiang Town, Baoan District, Shenzhen
鉴定依据 Inspection according to	国际海运危险货物规则 INTERNATIONAL MARITIME DANGEROUS GOODS CODE
检测报告编号 The No. test report	NCT19010054XB1-3
鉴定依据 Criteria	1) 《联合国危险货物运输的建议书规章范本》 2) 《国际海运危险货物规则》 3) 该物质的 UN38.3 报告 1) 《Technical Instructions for the Safe Transport of Dangerous Goods》 2) 《International Maritime Dangerous Goods》 3) The UN38.3 test report.

图片 (Photo):

样品 Samples:

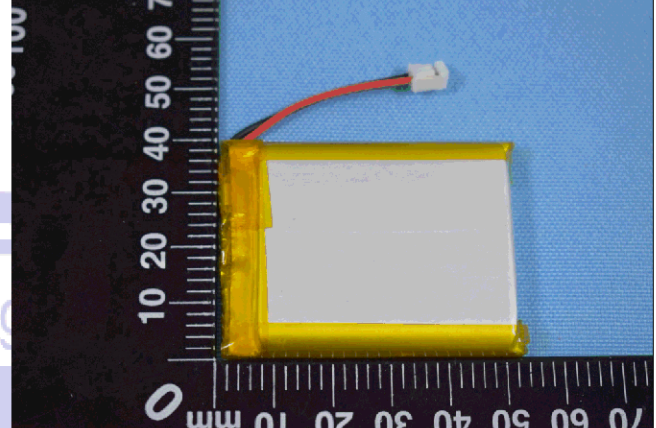
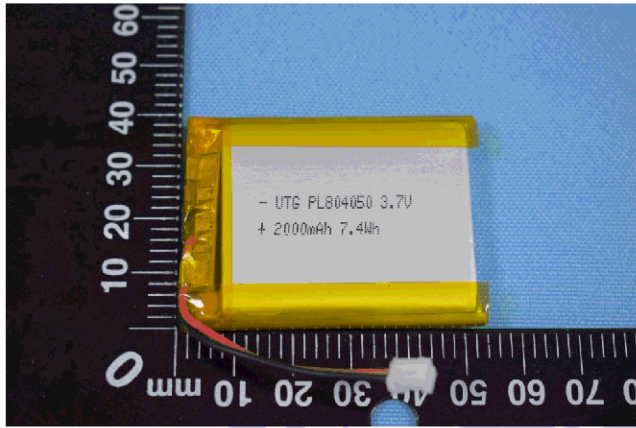

包装 Package:



注意事项

Important Notice

1. 本鉴定书依据本年度《国际海运危险货物规则》，委托人(托运人或代理人)提供的物品及其运输信息出具。

This certification is issued according to 《International Maritime Dangerous Goods》 published in the current year, the information of the goods and its shipment provided by the applicant (shipper or his agent).

2. 本鉴定书的鉴定结论仅对客户所送样品负责。由于客户提供的样品及其信息不真实而导致的一切后果均由客户负责。

The conclusion of this certification is responsible only for the sample provided by the applicant. The applicant should undertake the law responsibility that result from providing untruth sample and untruth information.

3. 本鉴定书不考虑国家及经营人差异。

The certification takes no account of the state and operator variations.

4. 本鉴定报告书涂改无效。

This report is invalid if altered.

5. 本鉴定报告书无负责人、审核人签名无效。

This report is invalid without the signatures of Approved and testing engineer.

6. 本鉴定报告书从 2019 年 03 月 08 日到 2019 年 12 月 31 日有效。

The report is valid from 2019-03-08 to 2019-12-31

试验单位：深圳诺测检测技术有限公司

Company: Shenzhen NCT Testing Technology Co., Ltd.

地 址：中国广东省深圳市宝安区西乡街道固戍航城大道绵商青年创业园 B 栋第 1 层

Address: 1 / F, No. B Building, Mianshang Younger Pioneer Park, Hangcheng Road,
Gushu Xixiang Street, Baoan District, Shenzhen, Guangdong, China

Hotline: 400-886-8419

Fax: 86-755-27790922

[http:// www.nct-testing.cn](http://www.nct-testing.cn)